

EUTIT, s.r.o.

Stará Voda 196

353 01 Mariánské Lázně

I. N.: 47714930

phone: +420 / 354 789122, +420 / 354 691301

fax: +420 / 354 691480

e-mail: eutit@eutit.cz <http://www.eutit.cz>

A. CHARACTERISTIC

EUCOR is a trade description of a corundum-baddeleyit material, if need be castings, manufactured by melting in electric arc furnace, by casting of a formed melt into moulds, by cooling and a possible additional machining. The raw material is crushed material ZAC 1681 (1711).

Under marking EUCOR a wide assortment of tiles, pipes, bends and other special shaped pieces is manufactured. These products are mainly distinguished for high abrasion resistance, chemical resistance, high heat resistance and a considerable compression strength.

Use: multilateral

Tiles: floors, walls and chutes with an extreme mechanical, chemical, abrasive stress, possibly with heat stress

Pipes, bends: suitable for hydraulic and mainly pneumatic transport of various, mainly abrasive materials, transported with a considerable speed and also at the high temperature

Special shaped pieces:

reducers, jets, cyclones, radiation plates and other forms as a replacement of the parts of high-alloy steel and castings and also if cast basalt is not sufficient due to its properties.

In general it can be said that EUCOR has several times higher abrasion resistance than cast basalt and higher in order than special alloy steel and cast iron.

Evaluation: Certificate of products

No. CO 3015-98-001

issued on 30. 01. 1998

CO 3015 TZÚS Prague

EUTIT, s.r.o.

I. N.: 47714930

Stará Voda 196

phone: +420 / 354 789122, +420 / 354 691301

353 01 Mariánské Lázně

fax: +420 / 354 691480

e-mail: eutit@eutit.cz <http://www.eutit.cz>

B. TECHNICAL DATA (MEAN VALUES)

1. Basic properties

Mohs hardness (ČSN EN 101)	: min. degree 9 ⁺
Specific mass (ČSN EN 993 - 2)	: 3850 - 3900 kg.m ⁻³
Volume mass (ČSN EN 993 - 1)	: min. 3500 kg.m ⁻³
Compression strength (ČSN EN 993 - 5)	: min. 300 MPa
Bending strength (ČSN EN 993 - 6)	: min. 50 MPa
True porosity (ČSN EN 993 - 1)	: max. 10 % of volume
Linear thermal expansivity (ČSN EN ISO 10545-8):	see graph on page 4
Sulphuric acid solubility (ČSN EN993 - 16)	: max. 0,75 % of mass
Sodium hydroxide insolubility (ČSN 72 5122)	: min. 98,5 % of mass
Deep abrasion - abrasion resistance (ČSN EN ISO 10545-6):	max. loss 30 mm ³
Thermal shocks resistance (DIN 51 068)	: min. 20 cycles 950/20°C

⁺ Diamond has the hardness according Mohs 10

2. Informative properties

Apparent porosity (ČSN EN 993 - 1)	: max. 5 % of volume
Thermal conductivity (ČSN EN 993 - 14)	: see graph on page 4
Modulus of elasticity in tension (procedure per par 13 of ON 70 1807/67)	: min. 12.10 ⁴ MPa
Vickers hardness (EN ISO 6507-1)	: min. 950 HV (MPa)

3. Chemical composition (% of mass) – standard values

SiO ₂	13 ~ 17
Al ₂ O ₃	49 ~ 52
ZrO ₂	30 ~ 33
Fe ₂ O ₃	~ 0,2
TiO ₂	~ 0,1
Na ₂ O + K ₂ O	1 ~ 2
CaO	~ 0,2

4. Mineralogical composition (% of mass) – standard values

corundum	48 ~ 50
baddeleyit	30 ~ 32
vitreous phase	18 ~ 20

EUTIT, s.r.o.

Stará Voda 196

353 01 Mariánské Lázně

I. N.: 47714930

phone: +420 / 354 789122, +420 / 354 691301

fax: +420 / 354 691480

e-mail: eutit@eutit.cz <http://www.eutit.cz>

5. Heat resistance

EUCOR is heat deformation resistant at load 0,2 MPa 1700°C. It has a relatively good thermal shocks resistance and as a wear resistant material it can be used without hazard up to 1000°C, for a short period up to 1100°C.

6. Chemical resistance

EUCOR is a completely resistant to all organic solvents, oil products and acids. It is also well resistant to alkaline solutions including inorganic ones it is very well resistant to all inorganic acids except hydrofluoric acid, which reacts, especially at high temperatures, with present silicon dioxide. It always depends on the concentration of the acting medium and mainly on the temperature, with whose increase chemical resistance of EUCOR decreases. Various mixtures of particular agents also affect it.

The comparison of basic properties of EUCOR with some other materials

Property	unit	ceramic tiling elements	cast basalt	EUCOR
Volume mass	kg . m ⁻³	1900 ~ 2500	2900 ~ 3000	3500
Compression strength	MPa	100 ~ 190	300 ~ 450	300
Bending strength	MPa	30 ~ 60	45	50
Deep abrasion - abrasion resistance	mm ³	140 ~ 200	110	30
Thermal shocks resistance		not determined	average	good
Application temperature	°C	200	400	1000

EUTIT, s.r.o.

Stará Voda 196

353 01 Mariánské Lázně

I. N.: 47714930

phone: +420 / 354 789122, +420 / 354 691301

fax: +420 / 354 691480

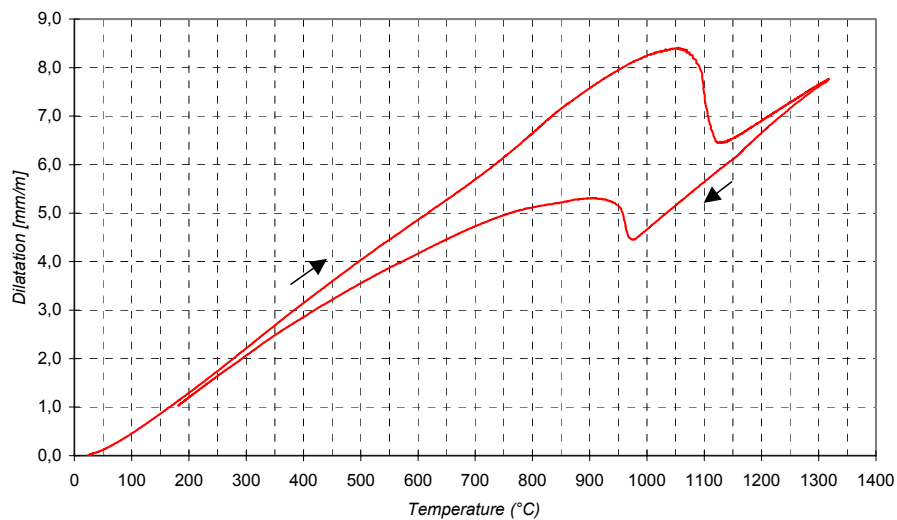
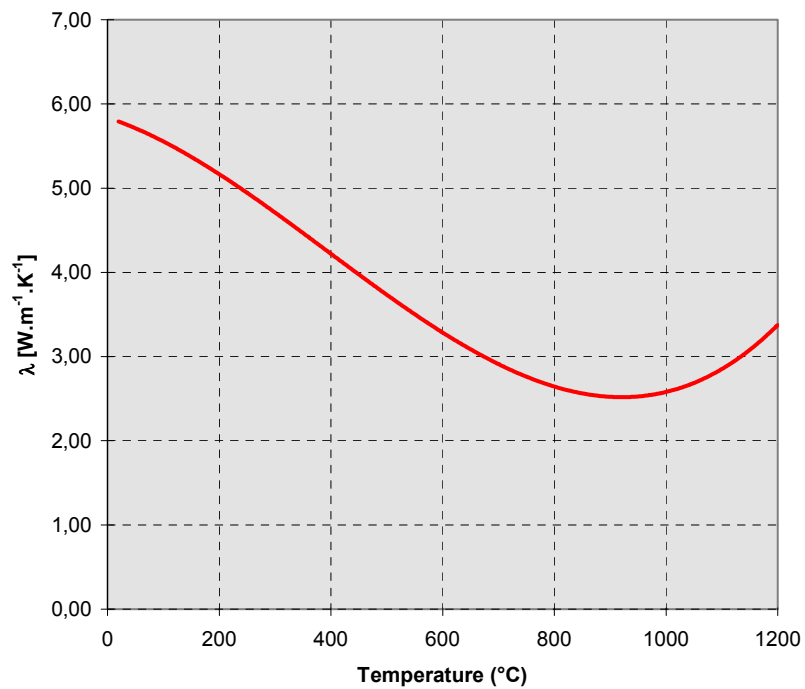
e-mail: eutit@eutit.cz <http://www.eutit.cz>**Dilatation curve****Thermal conductivity λ** 



EUTIT, s.r.o.

I. N.: 47714930

Stará Voda 196

phone: +420 / 354 789122, +420 / 354 691301

353 01 Mariánské Lázně

fax: +420 / 354 691480

e-mail: eutit@eutit.cz <http://www.eutit.cz>

C. SUPPLIER AND COMMERCIAL DATA

Manufacturer guarantees basic technical data according to this catalogue sheet. In case of need execution of the tests can be agreed according to respective standards.

Ordering:

During the order the following data must be agreed:

- a) indication of manufacturer
- b) type and size of product (drawing documentation)
- c) number of pcs
- d) delivery term
- e) total mass

Packaging: The products are transported as carload consignments freely located in covered transport means. As a protective interlined material the polystyrene, paper, sawn timber or other suitable material are used. In some cases, e.g. flat castings, these castings are also transported on pallets, banded, in foils.

Size and point of view of surface quality for particular products are stated in supplements of this catalogue sheet.

EUTIT, s.r.o.

Stará Voda 196

353 01 Mariánské Lázně

I. N.: 47714930

phone: +420 / 354 789122, +420 / 354 691301

fax: +420 / 354 691480

e-mail: eutit@eutit.cz <http://www.eutit.cz>

Fig. 1

1. Tiles of dimensions 200 x 200 x 30 mm with the mass of 1 pc approx. 4,2 kg are manufactured of rectangular tiles in a standard way.
2. In addition a quite extensive assortment of rectangular tiles up to the length (a) and width (b) 300 mm, thickness (t) 30, 40, 50 and 60 mm is manufactured. Tiles of a smaller surface dimensions and of the thickness 25 mm can exceptionally be manufactured.
3. All tiles are manufactured into sand moulds and they are double-sided smooth.
4. Dimensional tolerances of the length and width are at the tiles of all surface dimensions ± 2 mm. Allowed tolerance ± 2 mm is also at each thickness.
5. If for technical reasons different forms and dimensions than the above stated are required, after agreement between manufacturer and customer the tiles of various, even of non-rectangular ground plan forms and thickness can be supplied. In these cases manufacturer with customer also agree on the dimensional tolerances.
6. Rectangular tiles are indicated with the lengths of the sides and wall thickness. Their mass is calculated from volume mass 3500 kg.m^{-3} . This mass is only approximate, because the actual mass can differ within the bend of standardised tolerances for dimensions.
7. Technical requirements for the order are indication of the length, width, possibly angles at irregular tiles, of thickness and number of pcs.
8. Common provisions - Catalogue sheet E - 02.
9. Surface quality
Surface quality of the tiles is given by character of the material and the way of casting into sand moulds. Residues of the sand adhered from the mould are allowable. They must not have any defects, which could affect their function for the use determined. Cracks of the products are identified visually and by hammering (weight approx. 0,3 kg).

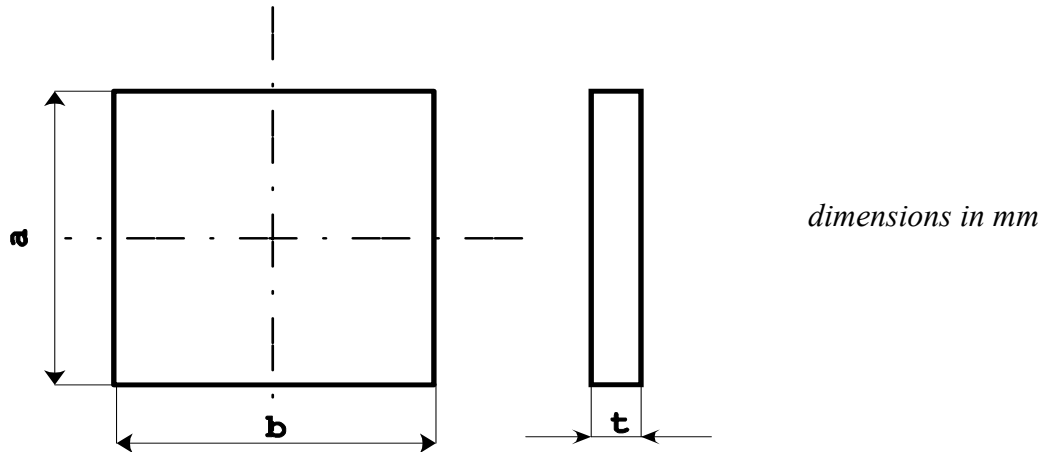

EUTIT, s.r.o.

I. N.: 47714930

Stará Voda 196

phone: +420 / 354 789122, +420 / 354 691301

353 01 Mariánské Lázně

fax: +420 / 354 691480

e-mail: eutit@eutit.cz <http://www.eutit.cz>

- 10.** At least 95 % of products must not have visible defects, which could affect surface quality of the tiles (see EN ISO 10545-2) and they must meet requirements for sampling (principal see EN ISO 10545-2).

EUTIT, s.r.o.

I. N.: 47714930

Stará Voda 196

phone: +420 / 354 789122, +420 / 354 691301

353 01 Mariánské Lázně

fax: +420 / 354 691480

e-mail: eutit@eutit.cz

<http://www.eutit.cz>

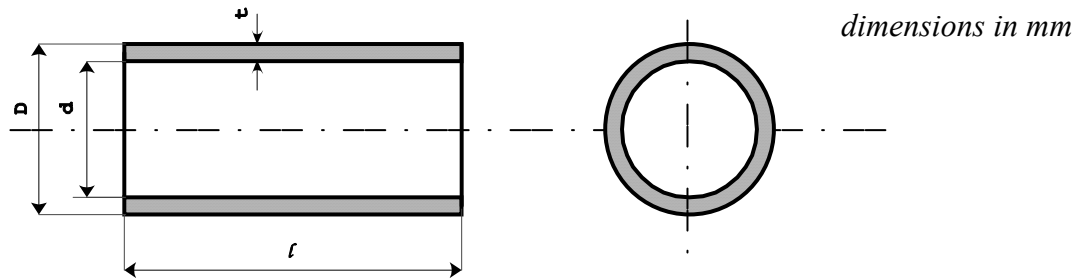

Fig. 1

Table No. 1 (liners)

Allowed tolerances	Allowed tolerances [mm]			
	d	D	t	l
82,5	82,5	132,5	25	500
100	100	150	25	500
125	125	175	25	500
150	150	200	25	500
175	175 ± 2	225 ± 2	25 ± 2	500 ± 2
204	204	254	25	500
225	225	275	25	500
254	254	304	25	500
303	303	353	25	500
356	356 ± 3	406 ± 3	25	333
400	400	450	25	333

EUTIT, s.r.o.

Stará Voda 196

353 01 Mariánské Lázně

I. N.: 47714930

phone: +420 / 354 789122, +420 / 354 691301

fax: +420 / 354 691480

e-mail: eutit@eutit.cz <http://www.eutit.cz>

1. Approximate weight of the liners is calculated from volume mass 3500 kg.m^{-3} according to the relation $M = 1,1 \cdot 10^{-5} \cdot l \cdot t \cdot (d + t)$. This mass is only approximate, because the actual mass can differ within the bend of standardised tolerances for dimensions. If we take into consideration the ordinary range of products (see table No. 1 on p.7) the mass can range from 15 kg to 39 kg.
2. In addition to the liners of standard inside diameter, length and thickness after agreement with customer the liners of other inside diameter, length and thickness can also be manufactured. The minimum inside diameter is as a rule 50 mm, maximum inside diameter 600 mm, the length 200, 250, 300, 333, 400 mm, thickness 27 - 30 mm, in exceptional cases also smaller, however at least 20 mm. The largest liner diameter are manufactured thicker and shorter.
3. Ovality (out-of-roundness) is defined within the allowed limit deviations of inside diameters according to table No. 1.
4. Technical requirements for the order
In the order for liners the inside diameter, length of the liner, thickness and number of pcs shall be stated. For example 254/500/25 indicates a liner of the inside diameter 254 mm, length 500 mm and wall thickness 25 mm.

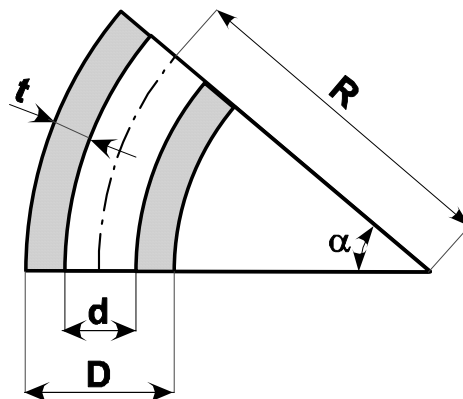

*dimensions in mm
angles in degrees*

Fig. 2

EUTIT, s.r.o.

Stará Voda 196

353 01 Mariánské Lázně

I. N.: 47714930

phone: +420 / 354 789122, +420 / 354 691301

fax: +420 / 354 691480

e-mail: eutit@eutit.cz <http://www.eutit.cz>**Table No. 2 (bends)**

Indication	Allowed tolerances				R [mm]
	d [mm]	D [mm]	t [mm]	* alfa [mm°]	
82,5	82,5 ± 2	132,5 ± 3	25	7, 5, 15, ±5 mm 30	750,
100	100	150	25		1000,
125	125	175 +3/-	25 ± 2		
150	150 +2/-3	200 2	25		
175	175	225	25		
204	204	254	25		1500, ±1 %
225	225 +2/-4	275 +4/-2	25 +3/-2		
254	254	304	25		2000,
303	303	353	25 +4/-2		
356	356 +3/-5	406 +5/-	25		2500,
		3	+5/-2		
400	400	450	25	3000	

* The tolerance of the limiting deviation „alfa“ related to the greatest length of the bend and is expressed in mm.

5. Approximate weight of the bend is calculated according to the relation

$M=1,919 \cdot 10^{-7} R \cdot t \cdot (d+t) \cdot \alpha$ and it is rounded off onto one decimal place. The considered volume mass is $3500 \text{ kg} \cdot \text{m}^3$. This mass is only approximate, because the actual mass can differ within the bend of standardised tolerances for dimensions.

(The bend of the radius $R = 2000 \text{ mm}$, thickness $t = 25 \text{ mm}$, inside diameter $d = 254 \text{ mm}$ and central angle $\alpha = 15^\circ$ has the weight $M = 40,2 \text{ kg}$.)

6. The bends of the same inside diameter are manufactured in various central angles and radii, stated in Table 2. In addition to standard inside diameters after agreement with customer also other bends of other inside diameters than those stated in Table No. 2 can be manufactured. The largest bend of inside diameter 600 mm are manufactured in radius 500 and 750 mm, central angle 15° and thickness 27 mm. In general it holds true that bends of the radius 1000 mm and larger are not manufactured any more at central angle 30° , bends of radius 2500 and 3000 mm are only manufactured at central angle 7,5 %.

7. Ovality (out-of-roundness) is defined within the allowed limit tolerances of bore of the bend.

8. Technical requirements for the order

EUTIT, s.r.o.

I. N.: 47714930

Stará Voda 196

phone: +420 / 354 789122, +420 / 354 691301

353 01 Mariánské Lázně

fax: +420 / 354 691480

e-mail: eutit@eutit.cz <http://www.eutit.cz>

In the order for bends the inside diameter, radius, central angle, wall thickness and number of pcs are stated. For example 254/1500/15 S = 25 indicates bend of the inside diameter 254 mm, radius 1500 mm, central angle 15° and wall thickness 25 mm.

9. Liners and bends are exclusively cast into sand moulds.

10. Common provisions - Catalogue sheet No. E - 02.

11. Surface quality

Surface quality of the liners and bends is given by character of the material and the way of casting into sand moulds. The residues of adhered sand from the mould are allowed. The products must not have cracks, passing through the whole wall thickness and they must not have defects, which could affect their function for the use determined. Cracks of the products are identified visually.

12. At least 95 % of products must not have visible defects, which could affect surface quality and they must meet requirements for sampling (principal see EN ISO 10545-1).

13. At the bends, sometimes also at the liners their dimensions are as a rule cast directly at the outer non-working side of the casting. The numbers are 2 cm high and protrude above the surface up to the height 2 - 3 mm.

EUTIT, s.r.o.

Stará Voda 196

353 01 Mariánské Lázně

I. N.: 47714930

phone: +420 / 354 789122, +420 / 354 691301

fax: +420 / 354 691480

e-mail: eutit@eutit.cz <http://www.eutit.cz>

The term other shaped pieces includes an extensive assortment of various radial plates, rings, reducers, jets, cyclones and other forms.

1. If at other shaped pieces the dimensional tolerances stated at the tiles, liners and bends (flat and hollow shaped pieces) can be used, these tolerances are taken into consideration. The allowed tolerances are always agreed with customer in advance.
2. All shaped pieces are cast into sand moulds.
3. Common procedures - Catalogue sheet No. E - 02.
4. Surface quality
The same procedures hold true for surface quality as for tiles (see section 9 on page 7) and for shaped pieces and arches (see section 13 on page 11). In principal it holds true that they must not have any defects, which could affect their function for the use determined.
5. At least 95% of products must not have visible defects, which could affect surface quality and they must meet requirements for sampling (principal see EN ISO 10545-1).
6. Technical requirements for the order
Each type of the casting must be clearly indicated, the drawing documentation is mostly a part of the order. The weight of the casting changes case by case and the volume mass considered is 3500 kg.m³.
7. In some cases the shaped pieces are as a rule indicated by numbers, possibly also by letters, which are directly cast on the non-working side of the shaped piece. The numbers and letters are 2 cm high and protrude above the surface up to the height 2 - 3 mm.